

PRACTICE REPORT 53

Application examples for planners of complex construction projects

VENTAFLEX®
More efficiency in air guidance



Special hygiene for meat processing

Application area for VENTAFLEX®:
Hygiene certified air ducts as well as operation
customized supply- and exhaust air boxes for a
clean working environment

More than hygienic air ducts: VENTAFLEX® realizes special supply- and exhaust air boxes

“Teamwork” with the customer: This is what perfect solutions look like.

Task

The degree of customer satisfaction has a name: Follow-up orders! VENTAFLEX® was also able to make this experience with one of the biggest German sausage specialty producers with its headquarters in the Westphalian Versmold.

Especially in the food producing industry – and here particularly in meat processing – the obligations for an orderly operation are extremely high. Cleanliness has the highest priority and in order to meet this requirement any interior of the production halls has to be germ-resistant and easy to clean to the greatest possible extent. Of course this also affects the system transporting the air for the ventilation: A clear case for the VDI 6022 certified VENTAFLEX® air ducts.

Including the installation and the materiality of the supply- and exhaust air boxes significantly more into the hygiene concept was new in the current order. Due to this the customer and VENTAFLEX® mutually developed individual, edge-clear components with easy to change grids being comfortable to clean with the high-pressure cleaner.

Idea, plan, realization: Such demanding assignments testify the customer's confidence in the expertise of VENTAFLEX® ... we say thank you for this

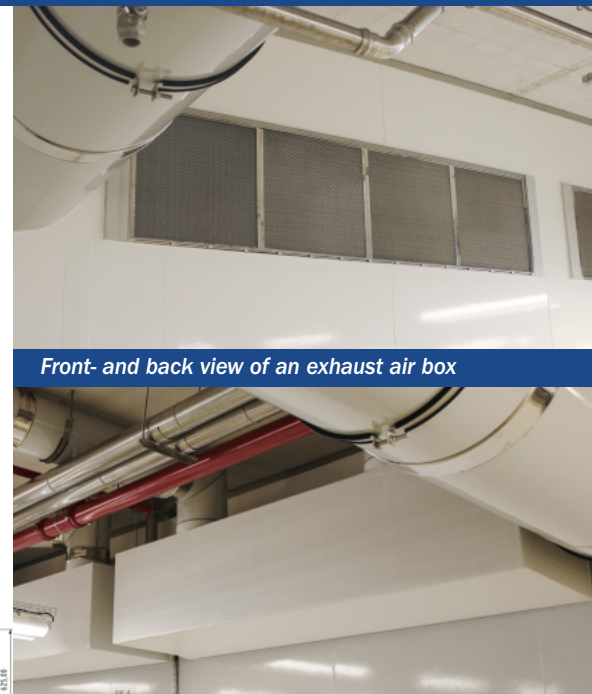
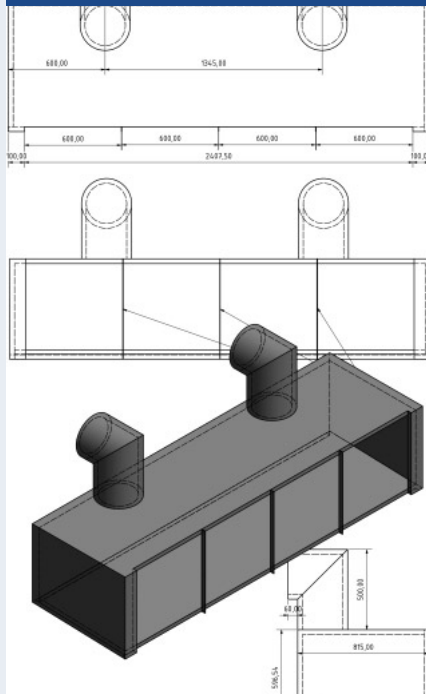

Advantages due to the VENTAFLEX® system

- + **Certified hygiene conformity** of the ducts according to VDI 6022
- + **Comfortable cleaning** of the smooth surface of the GRP material
- + **Individual adaption to the conditions** by customised production
- + **Reduction of the operating costs** – up to 40 % less energy loss, up to 10 % less pressure loss and up to 99 % less leakage loss
- + **Up to 70 % less weight** – important for statics and handling
- + **Ideal thermal insulation WLS 022** reduces condensate formation
- + **Combinability with other duct systems** by individual adaption

VENTAFLEX GmbH & Co. KG

Siemensstraße 46

D-48341 Altenberge

Tel +49 (0) 2505 - 938290

Fax +49 (0) 2505 - 93829 -10

info@ventaflex.de

www.ventaflex.de

VENTAFLEX®
More efficiency in air guidance